

OVERVIEW: SLIM PROFILE DOUBLE BRACKET SYSTEM S40/S45

The new slim profile double bracket is the latest addition to Acmeda's range. With a projection of only 85mm wide, it is available in two practical configurations; Top Front, featuring a front over roll on the top blind and Top Back offering standard back roll for both shades. The Top Front configuration provides pelmet finish to the shade, whilst the Top Back delivers the best possible light gap protection, especially on a face fix application.

AESTHETIC FEATURES

- Slimline profile.
- Contemporary colour range.

ASSEMBLY / INSTALLATION FEATURES

- Available in TOP FRONT and TOP BACK configurations.
- Universal top and face mounting.
- Easy link option for multi blind configurations.
- Longer & wider fixing plates for easier installation and increased strength.

FUNCTIONAL BENEFITS

- Ability to operate 2 blinds independently.
- Directional chain guard to avoid chain interference.
- Same side controls, available for left or right hand side.
- Motorisation & Spring booster compatible.

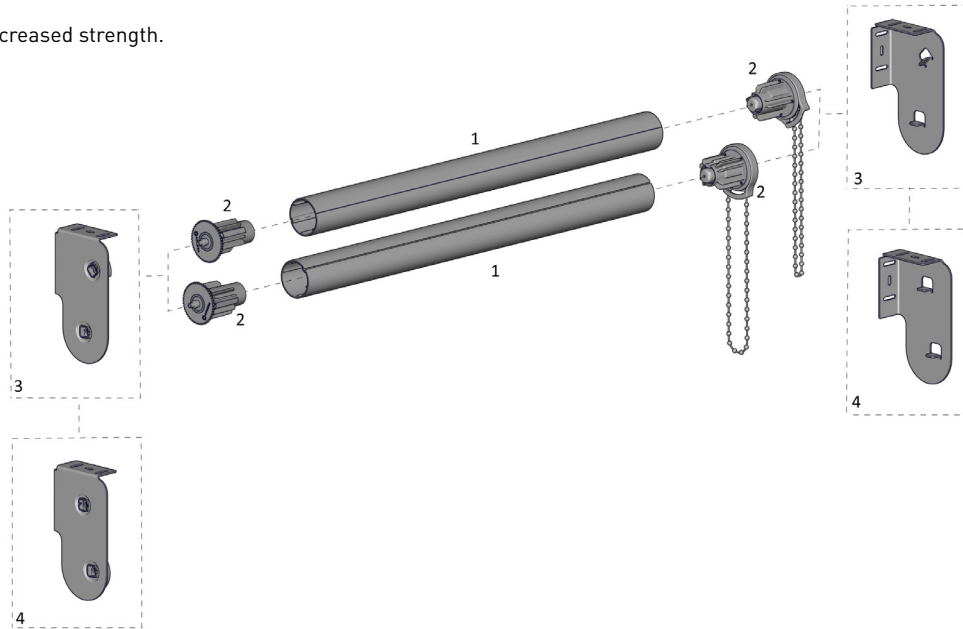

SYSTEM INDEX

1	Aluminium Tube - S40 or S45
	RB9#-04##-000580
2	FIXED GUIDE Chain Winder & EXTENDED Idler
	RB07-4#02-xxx070 - FIXED GUIDE 70 S40/45
	RB07-4#02-xxx090 - FIXED GUIDE 90 S40/45
3	SLIM PROFILE Double Bracket- Top Front
	RB08-8395-xxx148 - L/H Control
	RB08-8396-xxx148 - R/H Control
4	SLIM PROFILE Double Bracket - Top Back
	RB08-8397-xxx148 - L/H Control
	RB08-8398-xxx148 - R/H Control

xxx= colour ## = size

SYSTEM OPTIONS

<p>RB09 SLIM PROFILE BRACKETS</p>	<p>RB09 EXTENDED IDLER</p>
<p>EASY-LIFT SPRING ASSIST BOOSTER</p>	<p>SWIVEL 70 & 90 CHAIN WINDERS</p>

CONTROL OPTIONS

MOTORISED	CHAIN	SPRING

ADD ON SYSTEMS

EASY-LINK S40/ S45

COLOUR RANGE

pure white 069	sandstone 269	barley 283 [INDENT]	silver grey 338	black 050

SPECIFICATIONS: SLIM PROFILE DOUBLE BRACKET SYSTEM S40/S45

DIMENSIONS & CONFIGURATIONS

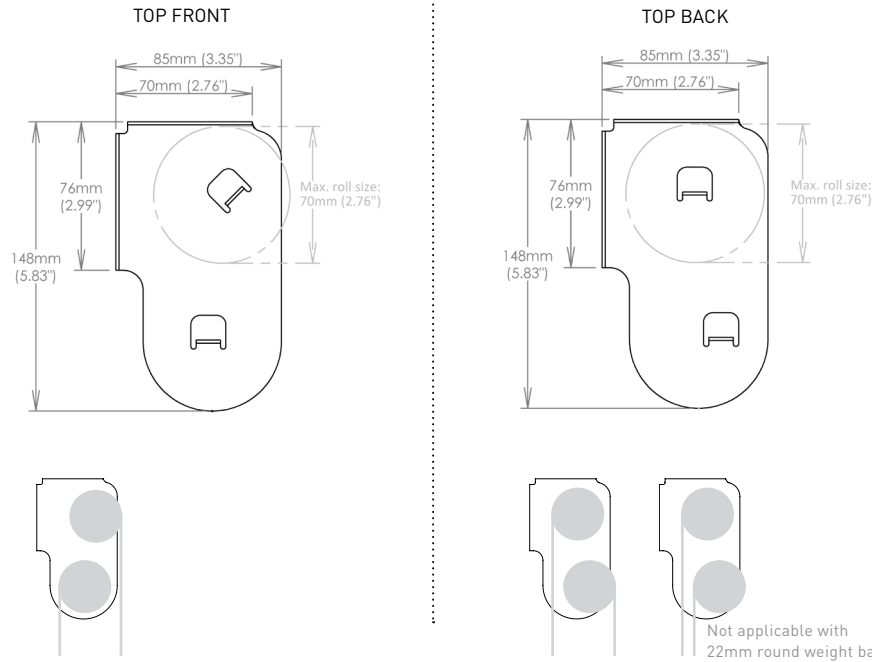

ALUMINIUM TUBES

S40 TUBE CAPACITY CHART

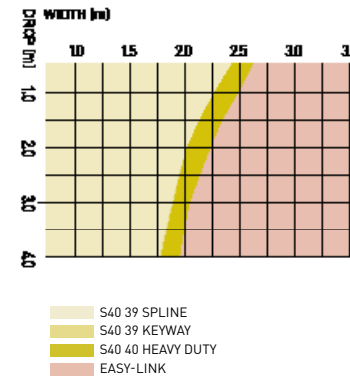

S45 TUBE CAPACITY CHART

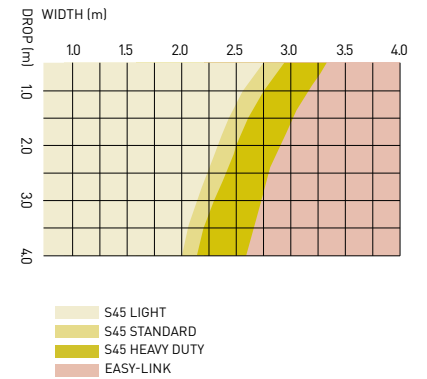

SYSTEM CAPACITY

S40/S45 CHAIN CONTROL

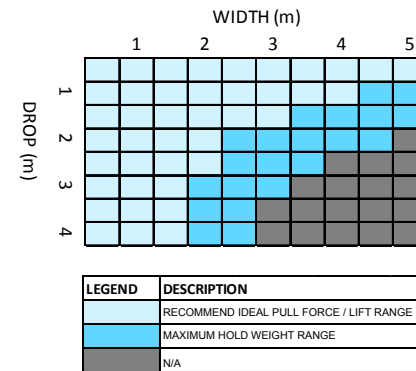

S40/S45 CHAIN CONTROL WITH BOOSTER

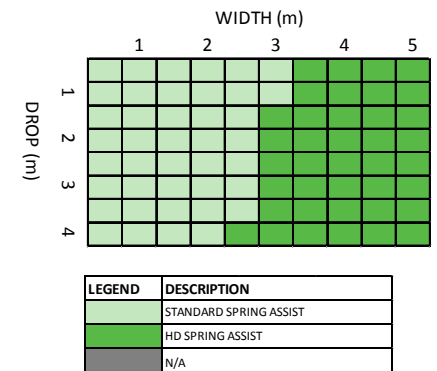

based on 420gsm fabric and oval base rail.

DEDUCTIONS

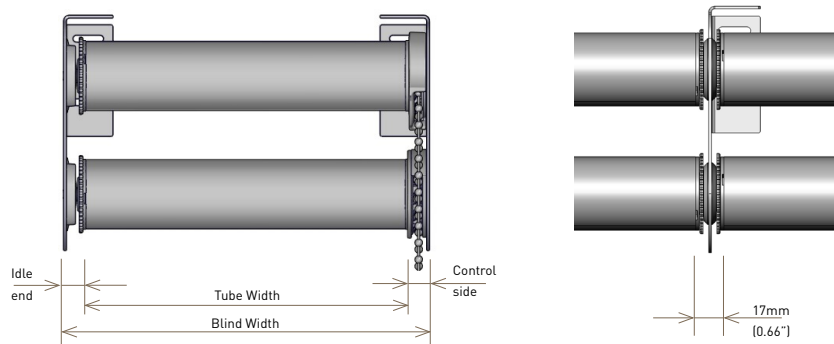

CHAIN WINDER SET	IDLE END SIDE	CONTROL SIDE	OVERALL DEDUCTION
RB07 FIXED GUIDE/ RB08 MKII	14mm [0.55"]	15mm [0.59"]	29mm [1.14"]
RB09	13mm [0.51"]	13mm [0.51"]	26mm [1.02"]

AUSTRALIA // EUROPE // ASIA

www.acmeda.com // info@acmeda.com

©Copyright 1990-2013 All Rights Reserved Acmeda [International Group]