

design
manufacture
supply

The preferred window covering
system supplier to the industry.

brilliance
in every room
INSPIRING INDOOR SOLUTIONS

The Roman Blind



Roman Blinds



A TOUCH OF CLASS

A time-honoured classic, a Roman blind from Uniline is the ultimate designer statement. The Roman style is essentially a series of fabric panels with distinct yet subtle fold lines that give it visual appeal when lowered, and create a neat stack of folds when raised. The elegant fabric folds blend seamlessly with traditional decors, and can also help soften an otherwise hard-edged modern interior. Have them custom-made in fabrics from Uniline's 5th Avenue, Mosaic or Uniweave ranges and, hey presto, watch your windows come alive. Choose a translucent fabric for living areas, and you'll see how Roman blinds filter natural light for a relaxing glow, while still retaining a good level of privacy. Guaranteed to look beautiful for years to come, Uniline Roman blinds come with a five-year components warranty.



SO MUCH TO LOVE ABOUT ROMAN BLINDS

Made to exacting standards, right here in Australia, Uniline Roman blinds will enhance the look of any window. Here's why:

- The innovative design means that battens are positioned without the need for unsightly staples or stitches, resulting in a quality finish.
- Lifting Uniline's Roman blinds is a breeze, thanks to the chain-driven mechanism. Even larger blinds weighing up to 8kg require only minimal effort.
- A self-guiding spool greatly reduces the risk of tangled cords, and ensures blinds can be raised or lowered without skewing.
- Child safety is paramount at Uniline, and that's why all our Roman blinds come with safety devices.

STYLE & EASE

- A Roman blind combines the functionality of a window shade with the decorative impact of a soft furnishing
- Easy to use and offer excellent light control
- Available with or without front battens in a range of colours to complement or contrast with the fabric
- Suits a wide range of fabric styles and colours





IT'S YOUR CHOICE.

The preferred window covering system to the industry.

Australia +61 7 3804 9000 | info@uniline.com.au | uniline.com.au

New Zealand +64 9 273 5026 | salesnz@uniline.com.au | uniline.co.nz



BILL OF MATERIALS FOR ROMAN BLIND.

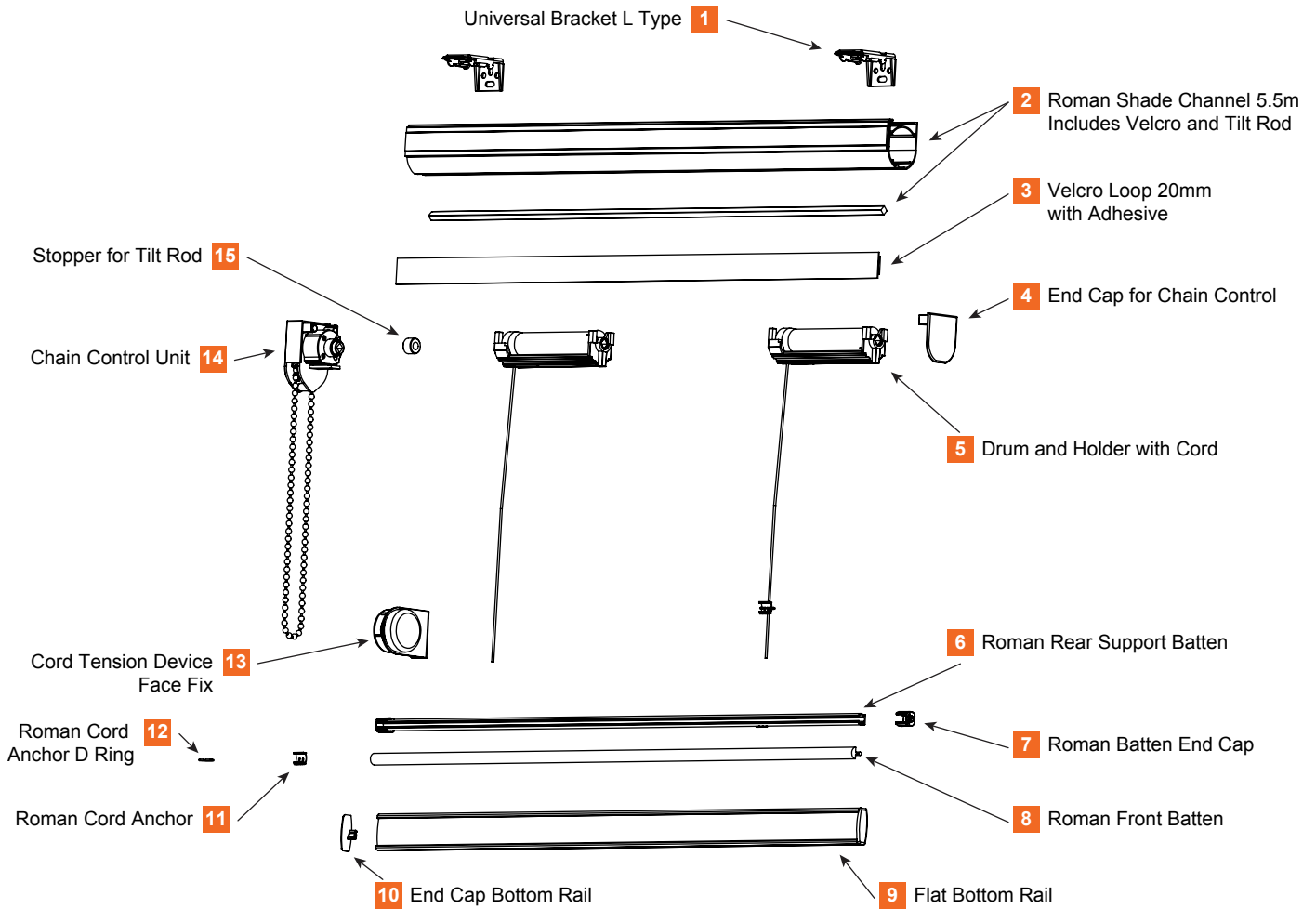

BOM NUMBER	PART NAMES	BOM NUMBER	PART NAMES
1	Universal Bracket L Type	8	Roman Front Batten
2	Roman Shade Channel 5.5m Includes Velcro and Tilt Rod	9	Flat Bottom Rail
3	Velcro Loop 20mm with Adhesive	10	End Cap Bottom Rail
4	End Cap for Chain Control	11	Roman Cord Anchor
5	Drum and Holder with Cord	12	Roman Cord Anchor D Ring
6	Roman Rear Support Batten	13	Cord Tension Device Face Fix
7	Roman Batten End Cap	14	Chain Control Unit
		15	Stopper for Tilt Rod

IT'S YOUR CHOICE.

The preferred window covering system supplier to the industry.

Australia +61 7 3804 9000 | info@uniline.com.au | uniline.com.au

New Zealand +64 9 273 5026 | salesnz@uniline.com.au | uniline.co.nz





ROMAN

INTERNAL BLINDS

ROMAN BLINDS

A TOUCH OF CLASS.

A time-honoured classic, a Roman blind from Uniline is the ultimate designer statement.

STYLE AND EASE

- A Roman blind combines the functionality of a window shade with the decorative impact of a soft furnishing.
- Easy to use and offer excellent light control.
- Available with or without front battens in a range of colours to complement or contrast with the fabric.
- Suits a wide range of fabric styles and colours.

The Roman style is essentially a series of fabric panels with distinct yet subtle fold lines that give it visual appeal when lowered and create a neat stack of folds when raised. The elegant fabric folds blend seamlessly with traditional decors and can also help soften an otherwise hard-edged modern interior.

Have them custom-made in fabrics from Uniline's ranges and, hey presto, watch your windows come alive.



Choose a translucent fabric for living areas and you'll see how Roman blinds filter natural light for a relaxing glow while still retaining a good level of privacy. Guaranteed to look beautiful for years to come, Uniline Roman blinds come with a five-year components warranty.



THE CHOICE IS YOURS

Made to exacting standards, right here in Australia, Uniline Roman blinds will enhance the look of any window. Here's why:

- The innovative design means that battens are positioned without the need for unsightly staples or stitches, resulting in a quality finish.
- Lifting Uniline's Roman blinds is a breeze thanks to the chain-driven mechanism. Even larger blinds weighing up to 8kg require only minimal effort.
- The self-guiding spool greatly reduces the risk of tangled cords and ensures blinds can be raised or lowered without skewing.
- Child safety is paramount at Uniline and that's why all our Roman blinds come with safety devices.
- Stainless steel cord clips keep the cords firmly in place.



ROMAN BLINDS ARE COMPATIBLE WITH THE FOLLOWING FABRIC RANGE:

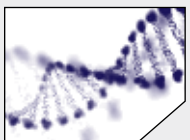

EVOLUTION



TEMPO



6TH AVENUE

For more information on the colours available for each fabric category, visit the Uniline website or contact Uniline Customer Service.

IT'S YOUR CHOICE.

The preferred window covering system supplier to the industry.

Australia Free Call: 1800 777 331 | sales@uniline.com.au | uniline.com.au

New Zealand Free Call: 0800 700 801 | salesnz@uniline.com.au | uniline.co.nz

